

## A General Shear Design Method



by Michael P. Collins, Denis Mitchell, Perry Adebar, and Frank J. Vecchio

*A simple, unified method is presented for the shear design of both prestressed concrete members and nonprestressed concrete members. The method can treat members subjected to axial tension or axial compression and treats members with and without web reinforcement. The derivation of the method is summarized and the predictions of the method are compared with those of the current ACI Code.*

**Keywords:** aggregate interlock; axial loads; building codes; crack width and spacing; reinforced concrete; shear strength; structural design.

The shear design provisions of the 1995 ACI Code<sup>1</sup> consist of about 43 empirical equations for different types of members and different types of loading, some of which are illustrated in Fig. 1. In 1973, the ACI-ASCE Shear Committee<sup>2</sup> expressed the hope that these "design regulations for shear strength can be integrated, simplified, and given a physical significance." As shown by the growth in the number of ACI shear design equations (see Fig. 2), the code has not met this desirable goal. It is interesting to note that, prior to 1963, the ACI shear design procedure was so simple that only four equations were required.

Most of the shear design equations given in Fig. 1 were introduced in either the 1963 or 1971 edition of the ACI Code.<sup>3,4</sup> These design equations were developed in the period following the 1955 air-force warehouse shear failures<sup>5</sup> and rely on the traditional concept of adding a concrete contribution  $V_c$  to the shear reinforcement contribution  $V_s$ , calculated on the basis of the 45 deg truss equation.

Since 1971 there has been an intensive research effort aimed at improving design methods for shear (see Fig. 3). The research has shown that, in general, the angle of inclination of the concrete compression is not 45 deg, and that equations based on a variable angle truss provide a more realistic basis for shear design. In addition, tests of reinforced concrete panels subjected to pure shear<sup>6</sup> improved the understanding of the stress-strain characteristics of diagonally cracked concrete. These stress-strain relationships made it possible to develop an analytical model, called the modified compression field theory, that proved capable of accurately predicting the response of reinforced concrete subjected to shear.

The objective of this paper is to present briefly a simple, general shear design method based on the modified compression field theory. This design method, recently introduced by Collins and Mitchell,<sup>7</sup> has been adopted by the Ontario Highway Bridge Design Code,<sup>8</sup> the Canadian Standards Association Concrete Design Code,<sup>9</sup> and the AASHTO LRFD specifications.<sup>10</sup> The method is summarized in Fig. 1.

### SHEAR RESPONSE OF CRACKED CONCRETE

Tests of reinforced concrete panels subjected to pure shear (see Fig. 4) demonstrated that even after cracking, tensile stresses exist in the concrete and that these stresses can significantly increase the ability of reinforced concrete to resist shear stresses.

Cracked reinforced concrete transmits load in a relatively complex manner involving opening or closing of pre-existing cracks, formation of new cracks, interface shear transfer at rough crack surfaces, and significant variation of the stresses in reinforcing bars due to bond, with the highest steel stresses occurring at crack locations. The modified compression field model attempts to capture the essential features of this behavior without considering all of the details. The crack pattern is idealized as a series of parallel cracks all occurring at angle  $\theta$  to the longitudinal direction. In lieu of following the complex stress variations in the cracked concrete, only the average stress state and the stress state at a crack are considered [see Fig. 4(b) and 4(c)]. As these two states of stress are statically equivalent, the loss of tensile stresses in the concrete at the crack must be replaced by increased steel stresses or, after yielding of some of the reinforcement at the crack, by shear stresses on the crack interface. The shear stress that can be transmitted across the crack will be a function of the crack width. Note that shear stress on the crack implies that the direction of principal stresses in the concrete changes at the crack location.

*ACI Structural Journal*, V. 93, No. 1, January-February 1996.

Received June 17, 1994, and reviewed under Institute publication policies. Copyright © 1995, American Concrete Institute. All rights reserved, including the making of copies unless permission is obtained from the copyright proprietors. Pertinent discussion will be published in the November-December 1996 *ACI Structural Journal* if received by July 1, 1996.

**Michael P. Collins**, FACI, is Bahen-Tanenbaum Professor of Civil Engineering at the University of Toronto, Toronto, Canada. He is a member of ACI Committee 358, Concrete Guidways, the ACI Technical Activities Committee subcommittee on High-Performance Concrete, and joint ACI-ASCE Committee 445, Shear and Torsion. He is a member of the Canadian Standards Association Committee for the Design of Concrete Structures.

**Denis Mitchell**, FACI, is a professor in the Department of Civil Engineering and Applied Mechanics at McGill University. He is a member of ACI Committee 408, Bond and Development of Reinforcement, and ACI-ASCE Committee 445, Shear and Torsion. He is Chairman of the Canadian Standards Association Committee for the Design of Concrete Structures.

ACI member **Perry Adebar** is an associate professor in the Department of Civil Engineering at the University of British Columbia, Vancouver, Canada. He is Secretary of JACI Committee 341, Earthquake Resistant Concrete Bridges, and joint ACI-ASCE computer-aided design of reinforced concrete.

ACI member **Frank J. Vecchio** is a professor in the Department of Civil Engineering at the University of Toronto. He is a member of ACI Committees 441, Reinforced Concrete Columns, and 447, Finite Element Analysis, and of the CEB Committee on Constitutive Modeling.

The average principal tensile strain  $\epsilon_1$  in the cracked concrete is used as a "damage indicator" that controls the average tensile stress  $f_1$  in the cracked concrete, the ability of the diagonally cracked concrete to carry compressive stresses  $f_2$ , and the shear stress  $v_{ci}$  that can be transmitted across a crack.

The principal compressive stress in the concrete  $f_2$  is related to both the principal compressive strain  $\epsilon_2$  and the principal tensile strain  $\epsilon_1$  in the following manner [see Fig. 5(a)]

$$f_2 = f_{2max} \left[ \frac{2\epsilon_2}{\epsilon_c'} - \left( \frac{\epsilon_2}{\epsilon_c'} \right)^2 \right] \quad (1)$$

where

$$f_{2max} = f_c' / (0.8 + 170\epsilon_1) \leq f_c' \quad (2)$$

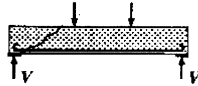
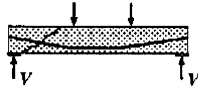
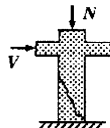
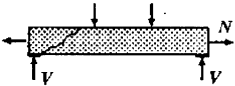
ACI Method		General Method
$V_n = V_c + V_s$		$V_n = V_c + V_s + V_p$
<p><b>Non-Prestressed Beams</b></p> 	$V_c = \left( 1.9 \sqrt{f_c'} + 2500 \rho_w \frac{V_u d}{M_u} \right) b_w d$ but $\frac{V_u d}{M_u} \leq 1.0$ $V_c \leq 3.5 \sqrt{f_c'} b_w d$ or $V_c = 2 \sqrt{f_c'} b_w d$ $V_s = \frac{A_v f_y d}{s}$ $V_n \leq 8 \sqrt{f_c'} b_w d$	$V_c = \beta \sqrt{f_c'} b_v d_v$ $V_s = \frac{A_v f_y}{s} d_v \cot \theta$ <p>where <math>\beta</math> and <math>\theta</math> are functions of the strain, <math>\epsilon_x</math>, shear stress, <math>v</math>, and crack spacing <math>s_x</math>            where <math>v = \frac{V_n - V_p}{b_v d_v}</math>            and <math>\epsilon_x = \frac{M_u / d_v + 0.5(N_u + V_u \cot \theta) - A_{ps} f_{pu}}{E_s A_s + E_p A_p}</math></p>
<p><b>Prestressed Beams</b></p> 	$V_c = \left( 0.6 \sqrt{f_c'} + 700 \frac{V_u d}{M_u} \right) b_w d$ but $2 \sqrt{f_c'} b_w d \leq V_c \leq 5 \sqrt{f_c'} b_w d$ or $V_c = V_{ci} = 0.6 \sqrt{f_c'} b_w d + V_d + \frac{V_i M_{cr}}{M_{max}}$ but $V_{ci} \geq 1.7 \sqrt{f_c'} b_w d$ and $V_c \leq V_{cw} = \left( 3.5 \sqrt{f_c'} + 0.3 f_{pc} \right) b_w d + V_p$ $V_s = \frac{A_v f_y d}{s} \leq 8 \sqrt{f_c'} b_w d$	
<p><b>Axial Compression and Shear</b></p> 	$V_c = \left( 1.9 \sqrt{f_c'} + 2500 \rho_w \frac{V_u d}{M_u - N_u \frac{(4h - d)}{8}} \right) b_w d$ $V_c \leq 3.5 \sqrt{f_c'} b_w d \sqrt{1 + \frac{N_u}{500 A_g}}$ $V_s = \frac{A_v f_y d}{s} \leq 8 \sqrt{f_c'} b_w d$	
<p><b>Axial Tension and Shear</b></p> 	$V_c = 2 \left( 1 + \frac{N_u}{500 A_g} \right) \sqrt{f_c'} b_w d$ $V_s = \frac{A_v f_y d}{s} \leq 8 \sqrt{f_c'} b_w d$	
<p><b>Detailing Rules</b></p> <ul style="list-style-type: none"> <li>● Reinforcement shall extend beyond the point at which it is no longer required to resist flexure for a distance equal to the effective depth of the member or <math>12d_b</math>, which is greater,...</li> <li>● Flexural reinforcement shall not be terminated in a tension zone unless               <ul style="list-style-type: none"> <li>● shear at cutoff <math>\leq 2/3</math> shear permitted, or</li> <li>● stirrup area, <math>A_v</math>, in excess of that required for shear and torsion, is provided ...                    ... <math>A_v \geq 60 b_w s f_y</math>, ... <math>s \leq d/8\beta_b</math>, or</li> <li>● for #11 bars or smaller: shear at the cutoff <math>\leq 3/4</math> shear permitted and continuing reinforcement provides double the area required for flexure at the cutoff.</li> </ul> </li> <li>● At simple supports and points of inflection, the diameter of the positive moment tension reinforcement shall be limited so that               <math display="block">l_d \leq \frac{M_u}{V_u} + l_a</math> </li> </ul>		<p><b>Detailing Rules</b></p> <p>Longitudinal steel must be detailed so that</p> $A_s f_y + A_{ps} f_{px} \geq \frac{M_u}{\phi d_v} + 0.5 \frac{N_u}{\phi} + \left( \frac{V_u}{\phi} - 0.5 V_s - V_p \right) \cot \theta$

Fig. 1—Comparison of ACI and proposed shear design approaches

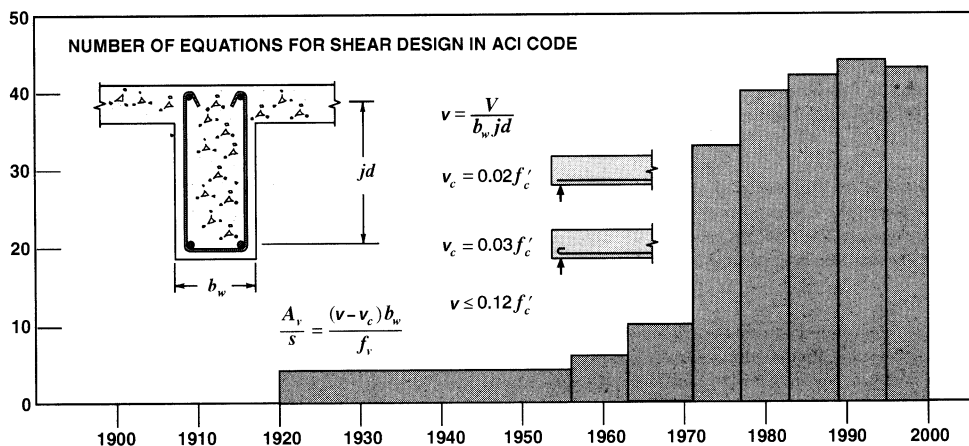


Fig. 2—Number of ACI shear design equations

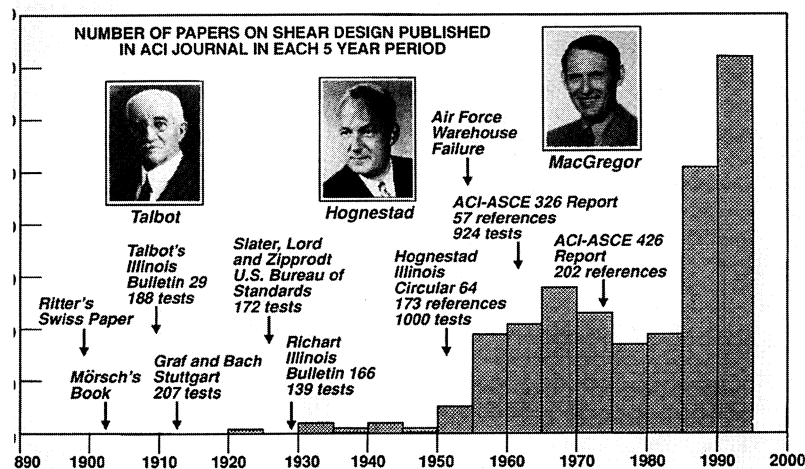


Fig. 3—Research into shear design methods

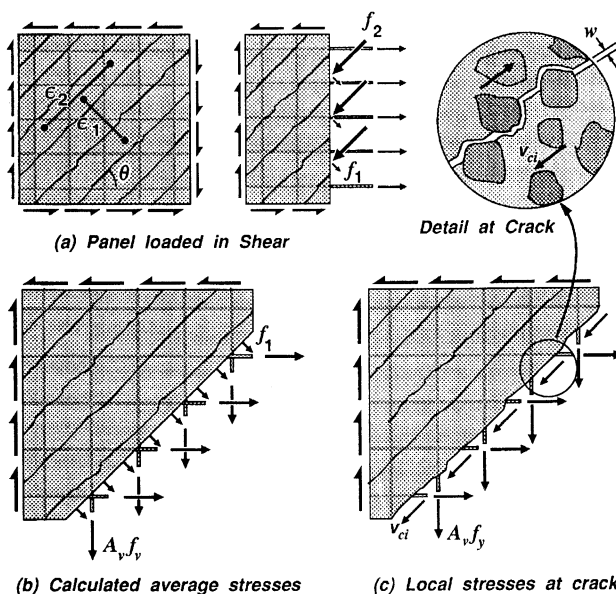


Fig. 4—Reinforced concrete panels subjected to shear

where  $\epsilon_c'$  has been taken as  $-0.002$ .

After cracking, the principal tensile stress in the concrete  $f_1$  is related to the principal tensile strain  $\epsilon_1$  as follows [see Fig. 5(b)]

$$f_1 = \frac{f_{cr}}{1 + \sqrt{500\epsilon_1}} \quad (4)$$

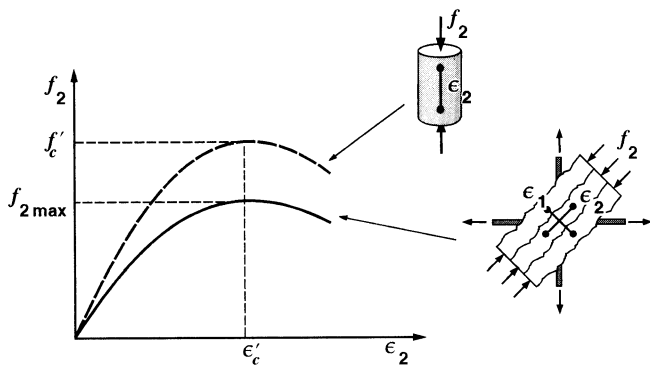
where the cracking stress  $f_{cr}$  can be taken as  $4\sqrt{f'_c}$  psi ( $0.33\sqrt{f'_c}$  MPa). For large values of  $\epsilon_1$ , the cracks will become wide and the magnitude of  $f_1$  will be controlled by the yielding of the reinforcement at the crack and by the ability to transmit shear stresses  $v_{ci}$  across the cracked interface [see Fig. 5(b)]. The shear stress that can be transmitted across the crack is a function of the crack width  $w$  and the aggregate size  $a$  [see Fig. 4(c)], as given by

$$v_{ci} = \frac{2.16\sqrt{f'_c}}{0.3 + \frac{24w}{a + 0.63}} \quad \text{psi and in.} \quad (5)$$

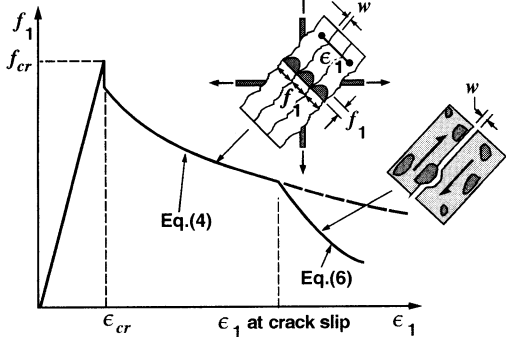
For MPa and mm units, replace the 2.16 by 0.18 and the 0.63 by 16.

From Eq. (1), the principal compressive strain for the loading portion of the stress-strain relationship is

$$\epsilon_2 = -0.002 \left( 1 - \sqrt{1 - f_2/f_{2max}} \right) \quad (3)$$



(a) Softening of compressive stress-strain curve due to transverse tensile strain



(b) Average tensile stresses in cracked concrete as a function of  $\epsilon_1$

Fig. 5—Stress-strain relationships for cracked concrete

If the stirrups have reached their yield stress and the crack begins to slip, the average tensile stress in the concrete  $f_1$  is limited to

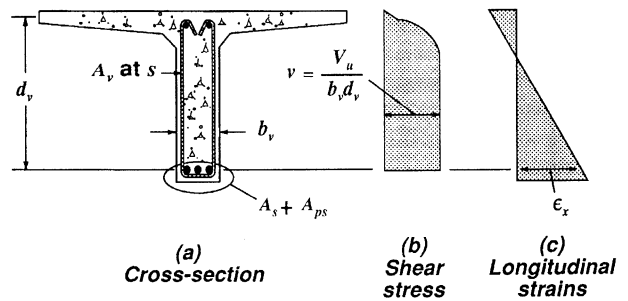
$$f_1 = v_{ci} \tan \theta \quad (6)$$

The previous stress-strain relationships, together with equilibrium and compatibility, can be used to predict the load-deformation response of reinforced concrete beams subjected to shear.<sup>11</sup> In addition, these relationships can be used as the basis for non-linear finite element formulations.<sup>12,13</sup>

### DESIGN OF STIRRUPS FOR SHEAR

In applying the modified compression field theory to the design of beams, it is appropriate to make a number of simplifying assumptions. As illustrated in Fig. 6, the shear stresses are assumed to be uniform over the effective shear area  $b_v d_v$ . The highest longitudinal strain  $\epsilon_x$  occurring within the web is used to calculate the principal tensile strain  $\epsilon_1$ . For design,  $\epsilon_x$  can be approximated as the strain in the flexural tension reinforcement. The determination of  $\epsilon_x$  for a nonprestressed beam is illustrated in Fig. 7. For a prestressed concrete member, the concrete surrounding the reinforcement will remain in compression until the applied tension exceeds the prestress force  $A_{ps} f_{po}$ , where  $f_{po}$  is the stress in the tendon when the surrounding concrete is at zero stress. In lieu of more accurate calculations,  $f_{po}$  can be taken as 1.10 times  $f_{se}$ .

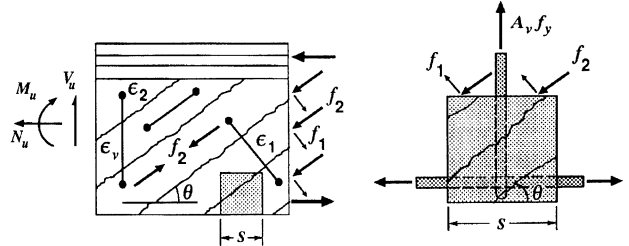
Hence, for design



(a) Cross-section

(b) Shear stress

(c) Longitudinal strains



(d) Biaxial strains in web

(e) Tension in web reinforcement

Fig. 6—Beam subjected to shear, moment, and axial load

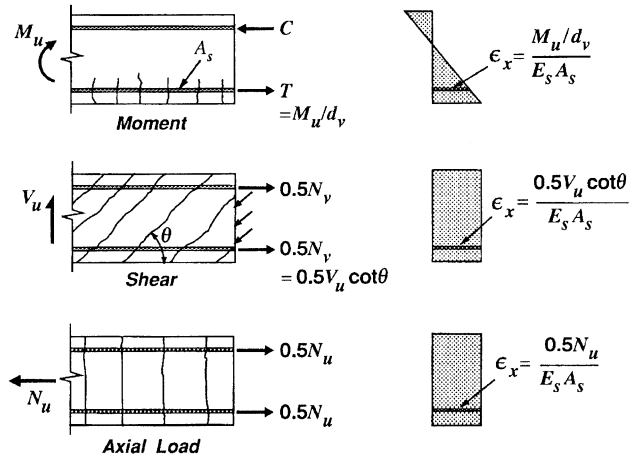


Fig. 7—Determination of strain  $\epsilon_x$  for nonprestressed beam

$$\epsilon_x = \frac{(M_u / d_v) + 0.5N_u + 0.5V_u \cot \theta - A_{ps} f_{po}}{E_s A_s + E_p A_{ps}} \geq 0 \quad (7)$$

ability, the principal tensile strain  $\epsilon_1$  can be related to the longitudinal strain  $\epsilon_x$ , the direction of the principal compressive stress  $\theta$ , and the magnitude of the principal compressive strain  $\epsilon_2$  in the following manner

$$\epsilon_1 = \epsilon_x + (\epsilon_x - \epsilon_2) \cot^2 \theta \quad (8)$$

Hence, as the longitudinal strain  $\epsilon_x$  becomes larger and the inclination  $\theta$  of the principal compressive stresses becomes smaller, the “damage indicator”  $\epsilon_1$  becomes larger. The nominal shear strength  $V_n$  of a member can be expressed as

$$V_n = V_c + V_s + V_p = f_1 b_v d_v \cot \theta + \frac{A_v f_y}{s} d_v \cot \theta + V_p$$

$$= \beta \sqrt{f'_c} b_v d_v + \frac{A_w f_y}{s} d_v \cot \theta + V_p \quad (9)$$

From the expressions for the average tensile stress in the cracked concrete [Eq. (4) and (6)], the tensile stress factor  $\beta$  can be determined as

$$\beta = \frac{4 \cot \theta}{1 + \sqrt{500 \epsilon_1}} \leq \frac{2.16}{0.3 + \frac{24w}{a + 0.63}} \quad \text{psi and in.} \quad (10)$$

For MPa and mm units, replace the 4 by 0.33, the 2.16 by 0.18, and the 0.63 by 16. The crack width  $w$  is taken as the crack spacing times the principal tensile strain  $\epsilon_1$ .

It can be seen from the previous expressions for  $\beta$  that as the tensile straining of the concrete increases (i.e.,  $\epsilon_1$  increases), the shear that can be resisted by tensile stresses in the concrete  $V_c$  decreases. The value of the principal tensile strain  $\epsilon_1$  will depend on the magnitudes of the longitudinal strain  $\epsilon_x$ , the principal compressive strain  $\epsilon_2$ , and the inclination  $\theta$  of the principal stresses [see Eq. (8)]. Strain  $\epsilon_2$  can be found from Eq. (3). In using this equation, the principal compressive stress  $f_2$  can be conservatively taken as

$$f_2 = v (\tan \theta + \cot \theta) \quad (11)$$

where

$$v = \frac{V_u - V_p}{b_v d_v} \quad (12)$$

From Eq. (3), (8), and (11),  $\epsilon_1$  can be expressed as

$$\epsilon_1 = \epsilon_x + \left[ \epsilon_x + 0.002 \left( 1 - \sqrt{1 - \frac{v}{f'_c} (\tan \theta + \cot \theta) (0.8 + 170 \epsilon_1)} \right) \right] \cot^2 \theta \quad (13)$$

**Table 1—Values of  $\theta$  and  $\beta$  for members with web reinforcement**

$\frac{v}{f'_c}$		Longitudinal strain $\epsilon_x \times 1000$					
		$\leq 0$	$\leq 0.25$	$\leq 0.50$	$\leq 1.00$	$\leq 1.50$	$\leq 2.00$
$\leq 0.050$	$\theta$ deg	27.0	28.5	29.0	36.0	41.0	43.0
	$\beta$	4.88	3.49	2.51	2.23	1.95	1.72
$\leq 0.075$	$\theta$ deg	27.0	27.5	30.0	36.0	40.0	42.0
	$\beta$	4.88	3.01	2.47	2.16	1.90	1.65
$\leq 0.100$	$\theta$ deg	23.5	26.5	30.5	36.0	38.0	39.0
	$\beta$	3.26	2.54	2.41	2.09	1.72	1.45
$\leq 0.150$	$\theta$ deg	25.0	29.0	32.0	36.0	36.5	37.0
	$\beta$	2.55	2.45	2.28	1.93	1.50	1.24
$\leq 0.200$	$\theta$ deg	27.5	31.0	33.0	34.5	35.0	36.0
	$\beta$	2.45	2.33	2.10	1.58	1.21	1.00
$\leq 0.250$	$\theta$ deg	30.0	32.0	33.0	35.5	38.5	41.5
	$\beta$	2.30	2.01	1.64	1.40	1.30	1.25

Note: for  $\beta$  values in MPa units divide given values by 12.

To use Eq. (9) to determine the required stirrups, the designer needs to determine appropriate values of  $\theta$  and  $\beta$ . For this purpose, Table 1 gives suitable values of  $\theta$  and  $\beta$  as functions of the longitudinal strain  $\epsilon_x$  and the shear stress level  $v/f'_c$ . While the values in Table 1 were calculated assuming a diagonal crack spacing of 12 in. (305 mm) and a maximum aggregate size of 3/4 in. (19 mm), it is believed that these values are appropriate for the full range of beams containing stirrups.

The  $\theta$  values given in Table 1 have been chosen to insure that the stirrup strain  $\epsilon_t$  is at least equal to 0.002 and to insure that, for highly stressed members, the principal compressive stress  $f_2$  in the concrete does not exceed the crushing strength  $f_{2max}$ . Within the range of values of  $\theta$  that satisfy these requirements, the values given in Table 1 will result in close to the smallest amount of shear reinforcement.

While the values in Table 1 can be applied to a range of values of  $\epsilon_x$  and  $v/f'_c$  (e.g.,  $\theta = 36$  deg and  $\beta = 2.09$  can be used provided that  $\epsilon_x$  is not greater than  $1 \times 10^{-3}$  and  $v/f'_c$  is not greater than 0.10), they were calculated for the upper limits of the range. Linear interpolation between the values given in Table 1 could be used, but it is usually not worth the effort.

At a particular section of a member subjected to  $V_u$ ,  $M_u$ , and  $N_u$ , the required shear strength is determined from

$$V_u \leq \phi V_n \quad (14)$$

where the strength reduction factor  $\phi$  can be taken as 0.85.

The amount of stirrups required at the section can then be found from Eq. (9) as

$$V_s \geq \frac{V_u}{\phi} - V_c - V_p \quad (15)$$

While this calculation is performed for a particular section, a shear failure caused by yielding of the stirrups involves yielding the reinforcement over a length of beam about  $d_v \cot \theta$  long. Hence, the calculations for one section can be taken as representing a length of beam,  $d_v \cot \theta$  long, with the calculated section being in the middle of this length. Thus, near a support, the first section to be checked is the section  $0.5 d_v \cot \theta$  from the face of the support. Near concentrated loads, sections closer than  $0.5 d_v \cot \theta$  to the load need not be checked. As a simplification, the term  $0.5 d_v \cot \theta$  may be taken as  $d_v$ . Since 1963, the ACI Code has required that at least a minimum area of stirrups be provided whenever  $V_u$  exceeds one-half of the shear strength provided by the concrete. For the design method presented in this paper, it is recommended that a minimum area of stirrups be provided if

$$V_u > 0.5 \phi (V_c + V_p) \quad (16)$$

where the minimum requirement is

$$\frac{A_w f_y}{b_w s} \geq 0.72 \sqrt{f'_c} \quad \text{psi}$$

$$= \beta \sqrt{f'_c} b_v d_v + \frac{A_w f_y}{s} d_v \cot \theta + V_p \quad (9)$$

From the expressions for the average tensile stress in the cracked concrete [Eq. (4) and (6)], the tensile stress factor  $\beta$  can be determined as

$$\beta = \frac{4 \cot \theta}{1 + \sqrt{500 \epsilon_1}} \leq \frac{2.16}{0.3 + \frac{24w}{a + 0.63}} \quad \text{psi and in.} \quad (10)$$

For MPa and mm units, replace the 4 by 0.33, the 2.16 by 0.18, and the 0.63 by 16. The crack width  $w$  is taken as the crack spacing times the principal tensile strain  $\epsilon_1$ .

It can be seen from the previous expressions for  $\beta$  that as the tensile straining of the concrete increases (i.e.,  $\epsilon_1$  increases), the shear that can be resisted by tensile stresses in the concrete  $V_c$  decreases. The value of the principal tensile strain  $\epsilon_1$  will depend on the magnitudes of the longitudinal strain  $\epsilon_x$ , the principal compressive strain  $\epsilon_2$ , and the inclination  $\theta$  of the principal stresses [see Eq. (8)]. Strain  $\epsilon_2$  can be found from Eq. (3). In using this equation, the principal compressive stress  $f_2$  can be conservatively taken as

$$f_2 = v (\tan \theta + \cot \theta) \quad (11)$$

where

$$v = \frac{V_n - V_p}{b_v d_v} \quad (12)$$

From Eq. (3), (8), and (11),  $\epsilon_1$  can be expressed as

$$\epsilon_1 = \epsilon_x + \left[ \epsilon_x + 0.002 \left( 1 - \sqrt{1 - \frac{v}{f'_c} (\tan \theta + \cot \theta) (0.8 + 170 \epsilon_1)} \right) \right] \cot^2 \theta \quad (13)$$

**Table 1—Values of  $\theta$  and  $\beta$  for members with web reinforcement**

$\frac{v}{f'_c}$		Longitudinal strain $\epsilon_x \times 1000$					
		$\leq 0$	$\leq 0.25$	$\leq 0.50$	$\leq 1.00$	$\leq 1.50$	$\leq 2.00$
$\leq 0.050$	$\theta$ deg	27.0	28.5	29.0	36.0	41.0	43.0
	$\beta$	4.88	3.49	2.51	2.23	1.95	1.72
$\leq 0.075$	$\theta$ deg	27.0	27.5	30.0	36.0	40.0	42.0
	$\beta$	4.88	3.01	2.47	2.16	1.90	1.65
$\leq 0.100$	$\theta$ deg	23.5	26.5	30.5	36.0	38.0	39.0
	$\beta$	3.26	2.54	2.41	2.09	1.72	1.45
$\leq 0.150$	$\theta$ deg	25.0	29.0	32.0	36.0	36.5	37.0
	$\beta$	2.55	2.45	2.28	1.93	1.50	1.24
$\leq 0.200$	$\theta$ deg	27.5	31.0	33.0	34.5	35.0	36.0
	$\beta$	2.45	2.33	2.10	1.58	1.21	1.00
$\leq 0.250$	$\theta$ deg	30.0	32.0	33.0	35.5	38.5	41.5
	$\beta$	2.30	2.01	1.64	1.40	1.30	1.25

Note: for  $\beta$  values in MPa units divide given values by 12.

To use Eq. (9) to determine the required stirrups, the designer needs to determine appropriate values of  $\theta$  and  $\beta$ . For this purpose, Table 1 gives suitable values of  $\theta$  and  $\beta$  as functions of the longitudinal strain  $\epsilon_x$  and the shear stress level  $v/f'_c$ . While the values in Table 1 were calculated assuming a diagonal crack spacing of 12 in. (305 mm) and a maximum aggregate size of 3/4 in. (19 mm), it is believed that these values are appropriate for the full range of beams containing stirrups.

The  $\theta$  values given in Table 1 have been chosen to insure that the stirrup strain  $\epsilon_s$  is at least equal to 0.002 and to insure that, for highly stressed members, the principal compressive stress  $f_2$  in the concrete does not exceed the crushing strength  $f_{2max}$ . Within the range of values of  $\theta$  that satisfy these requirements, the values given in Table 1 will result in close to the smallest amount of shear reinforcement.

While the values in Table 1 can be applied to a range of values of  $\epsilon_x$  and  $v/f'_c$  (e.g.,  $\theta = 36$  deg and  $\beta = 2.09$  can be used provided that  $\epsilon_x$  is not greater than  $1 \times 10^{-3}$  and  $v/f'_c$  is not greater than 0.10), they were calculated for the upper limits of the range. Linear interpolation between the values given in Table 1 could be used, but it is usually not worth the effort.

At a particular section of a member subjected to  $V_u$ ,  $M_u$ , and  $N_u$ , the required shear strength is determined from

$$V_u \leq \phi V_n \quad (14)$$

where the strength reduction factor  $\phi$  can be taken as 0.85.

The amount of stirrups required at the section can then be found from Eq. (9) as

$$V_s \geq \frac{V_u}{\phi} - V_c - V_p \quad (15)$$

While this calculation is performed for a particular section, a shear failure caused by yielding of the stirrups involves yielding the reinforcement over a length of beam about  $d_v \cot \theta$  long. Hence, the calculations for one section can be taken as representing a length of beam,  $d_v \cot \theta$  long, with the calculated section being in the middle of this length. Thus, near a support, the first section to be checked is the section  $0.5 d_v \cot \theta$  from the face of the support. Near concentrated loads, sections closer than  $0.5 d_v \cot \theta$  to the load need not be checked. As a simplification, the term  $0.5 d_v \cot \theta$  may be taken as  $d_v$ . Since 1963, the ACI Code has required that at least a minimum area of stirrups be provided whenever  $V_u$  exceeds one-half of the shear strength provided by the concrete. For the design method presented in this paper, it is recommended that a minimum area of stirrups be provided if

$$V_u > 0.5 \phi (V_c + V_p) \quad (16)$$

where the minimum requirement is

$$\frac{A_w f_y}{b_w s} \geq 0.72 \sqrt{f'_c} \quad \text{psi}$$

For MPa units replace the 0.72 by 0.06.

## DESIGN OF LONGITUDINAL REINFORCEMENT

Fig. 8 illustrates the influence of shear on the tensile forces in the longitudinal reinforcement. While the moment is zero at the simple support B, there still needs to be considerable tension in the longitudinal reinforcement near the support. The required tension in the bottom reinforcement at Support B can be determined from the free body diagram in Fig. 8(b) by taking moments about Point C and assuming that the aggregate interlock force in the crack that contributes to  $V_c$  has a negligible moment about Point C. For this nonprestressed beam, the tensile force required at the inner edge of the bearing area is

$$T = \left( \frac{V_u}{\phi} - 0.5V_s \right) \cot \theta \quad (17)$$

Eq. (17) gives the additional tension due to shear. Hence, at a section subjected to a shear  $V_u$ , a moment  $M_u$ , and an axial force  $N_u$ , the longitudinal reinforcement on the flexural tension side of the member must satisfy

$$A_s f_y + A_{ps} f_{ps} \geq \frac{M_u}{\phi d_v} + 0.5 \frac{N_u}{\phi} + \left( \frac{V_u}{\phi} - 0.5V_s - V_p \right) \cot \theta \quad (18)$$

At maximum moment locations, the shear force changes sign and hence, the inclination of the diagonal compressive stresses changes. At direct supports and point loads, this change of inclination is associated with a fan-shaped pattern of compressive stresses radiating from the point load or the direct support, as shown in Fig. 8(a). This fanning of the diagonal stresses reduces the tension in the longitudinal reinforcement caused by the shear (i.e., angle  $\theta$  becomes steeper). Due to this effect, tension in the reinforcement does not exceed that due to the maximum moment alone.

## MEMBERS WITHOUT WEB REINFORCEMENT

In evaluating the  $\beta$  factors given in Table 1, it was assumed that the diagonal cracks in webs containing stirrups would be spaced about 12 in. (305 mm) apart. For members not containing web reinforcement, this assumption may be unconservative; hence, it is inappropriate to use the  $\beta$  factors in Table 1 to evaluate the shear strength of members without web reinforcement.

For members without stirrups, the ability of the cracked concrete to transmit shear is primarily governed by the width of the diagonal cracks [see Eq. (10)]. The crack width can be taken as the principal tensile strain  $\epsilon_1$  multiplied by the crack spacing. Hence, for a given value of  $\epsilon_1$ , the shear strength will be a function of the crack spacing, with more widely spaced cracks resulting in lower shear capacities.

Fig. 9 illustrates the assumptions made in this design method concerning the crack spacings. For members without stirrups, the diagonal cracks will become more widely spaced as  $\theta$  approaches zero. The crack spacing when  $\theta = 90$  deg is called  $s_x$ , and this spacing is primarily a function of the maximum distance between reinforcing bars or between reinforcing bars and the flexural compression zone.

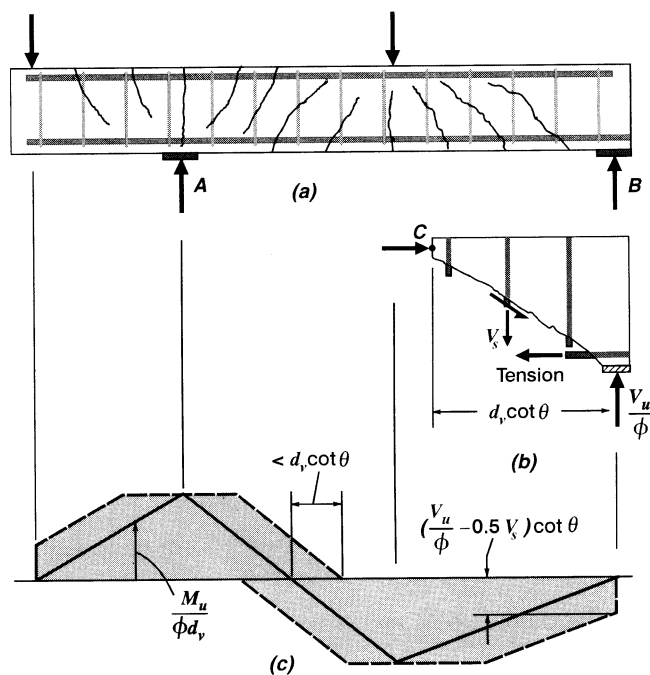


Fig. 8—Influence of shear on forces in longitudinal reinforcement

The factor  $\beta$ , which is the indicator of the ability of the cracked concrete to transmit shear, is a function of  $\theta$ ,  $\epsilon_1$ , and  $s_x$ . For given values of  $\epsilon_x$  and  $s_x$  and a chosen value of  $\theta$ , the factor  $\beta$  can be calculated from Eq. (9), (10), (12), and (13). Table 2 lists the values of  $\theta$  that will result in the highest  $\beta$  values for cracked concrete. The  $\beta$  values in Table 2 were derived assuming that the maximum aggregate size  $a$  was 3/4 in. (19 mm). However, the tabulated values can be used for other aggregate sizes by using an equivalent spacing parameter  $s_{xe}$  [see Eq. (10)] such that

$$s_{xe} = s_x \frac{1.38}{a + 0.63} \text{ in.} \quad (19)$$

For mm units, replace the 1.38 by 35 and the 0.63 by 16. For members without well-distributed crack control reinforcement, the crack spacing parameter  $s_x$  will increase as the member size increases. It is apparent from Table 2 that an increase in  $s_x$  results in a decrease in shear capacity.

Convincing evidence of the reduction in shear stress capacity that occurs as members become larger was provided by an extensive experimental program conducted in Japan by Shioya, et al.<sup>14,15</sup> In the program, lightly reinforced beams without stirrups and having effective depths  $d$  ranging from 4 to 118 in. (100 to 3000 mm) were uniformly loaded until failure. Fig. 10 compares the observed failure shear stresses for one series of these beams with the failure shears predicted by both the 1995 ACI Code<sup>1</sup> expressions and the general method. It can be seen that the largest beam in this series failed at a shear stress less than one-half of the failure shear predicted by the 1995 ACI Code equations.

## PROPOSED SHEAR DESIGN PROCEDURE

The general equations of the modified compression field theory, which are intended to account for the complex behavior of diagonally cracked concrete, are more suited for computer solutions (e.g., see program RESPONSE) than for hand calculations. With the  $\theta$  and  $\beta$  tables, the method becomes simple enough to solve by hand. For design, the steps are as follows:

Step 1—At the design section, calculate the shear stress  $v$  from Eq. (12).

Step 2—Calculate the longitudinal strain  $\epsilon_x$  from Eq. (7).

Step 3—For members with web reinforcement, choose the values of  $\theta$  and  $\beta$  from Table 1. For members without web reinforcement, choose the values of  $\theta$  and  $\beta$  from Table 2.

Step 4—For members without web reinforcement, use Eq. (9) to determine the nominal strength. For members with web reinforcement, use Eq. (9) to determine the required amount of web reinforcement.

Step 5—Use Eq. (18) to check the capacity of the longitudinal reinforcement.

## EXPERIMENTAL VERIFICATION

The ACI Code shear design expressions were obtained by first categorizing beams and columns into the following groups: nonprestressed members subjected to shear and flexure only; nonprestressed members subjected to axial compression; nonprestressed members subjected to axial tension; and prestressed members.

For each of the previous groups, an empirical equation was developed to provide a good fit to the available experimental data. Most of the equations were derived in the 1962 ACI/ASCE Shear Committee report<sup>16</sup> using the data available at that time.

In contrast, the shear design method in this paper was derived from the modified compression field theory that is based on equilibrium, compatibility, and the stress-strain characteristics of cracked reinforced concrete. In this fundamental approach, no fitting factors were employed to match the predictions to available beam tests. Thus, it is of considerable interest to compare the accuracy of the equations resulting from this new method with the accuracy of the traditional ACI equations.

In Fig. 11 the experimentally determined failure shears from 528 tests were compared to the failure shears predicted by both the ACI equations and the method presented in this paper. These tests encompass a wide range of cross-sectional shapes, sizes, material properties, and types of loading, as summarized in Table 3. The specimens selected were those that failed primarily due to high shear stresses. Specimens with short shear spans were excluded because such members should be designed using either strut-and-tie models<sup>12,17,18</sup> or the ACI deep-beam equations,<sup>1</sup> rather than the sectional design approaches described in this paper.

As seen in Fig. 11, the proposed general method predicts the failure shears more accurately than the equations of the current ACI Code. Table 3 indicates situations where the ACI shear design method can be very inaccurate. These situations include large, lightly reinforced members and members subjected to high axial compression.

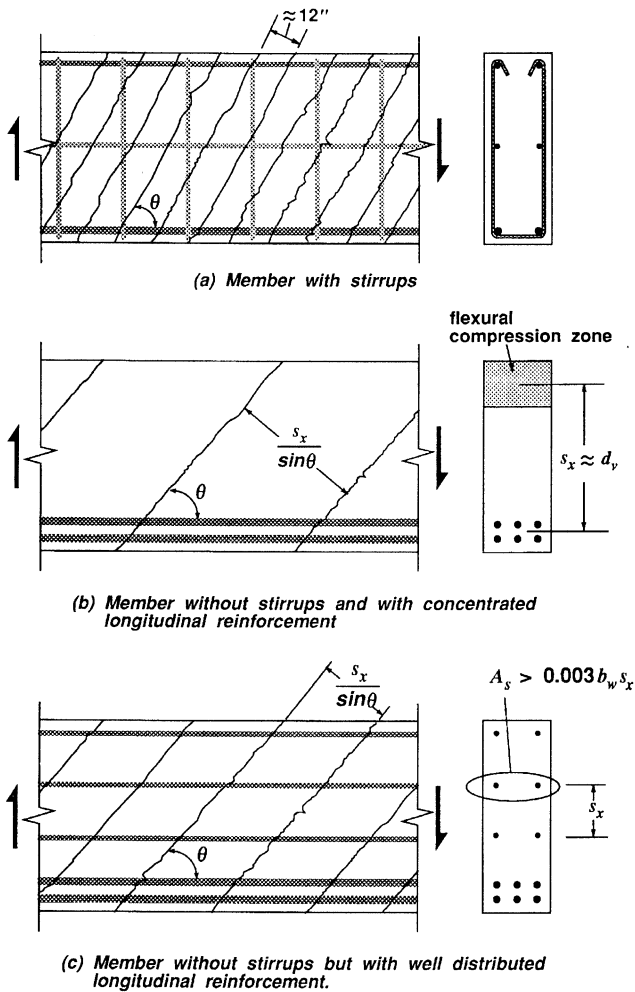


Fig. 9—Influence of reinforcement on spacing of diagonal cracks

Table 2—Values of  $\theta$  and  $\beta$  for members without web reinforcement

$s_x$		Longitudinal strain $\epsilon_x \times 1000$					
		$\leq 0$	$\leq 0.25$	$\leq 0.50$	$\leq 1.00$	$\leq 1.50$	$\leq 2.00$
$\leq 5$ in.	$\theta$ deg	27.0	29.0	31.0	34.0	36.0 deg	38.0 deg
	$\beta$	4.94	3.78	3.19	2.56	2.19	1.93
$\leq 10$ in.	$\theta$ deg	30.0	34.0	37.0	40.0	43.0	45.0 deg
	$\beta$	4.65	3.45	2.83	2.19	1.87	1.65
$\leq 15$ in.	$\theta$ deg	32.0	37.0	40.0	45.0	48.0	50.0 deg
	$\beta$	4.47	3.21	2.59	1.98	1.65	1.45
$\leq 25$ in.	$\theta$ deg	35.0	41.0	45.0	51.0	54.0	57.0 deg
	$\beta$	4.19	2.85	2.26	1.69	1.40	1.18
$\leq 50$ in.	$\theta$ deg	38.0	48.0	53.0	59.0	63.0	66.0 deg
	$\beta$	3.83	2.39	1.82	1.27	1.00	0.83
$\leq 100$ in.	$\theta$ deg	42.0	55.0	62.0	69.0	72.0	75.0 deg
	$\beta$	3.47	1.88	1.35	0.87	0.65	0.52

Note: For  $\beta$  values in MPa units divide given values by 12.

sion where the ACI equations can be very unconservative. On the other hand, for uniformly loaded members, members with inclined prestressing tendons, and members subjected to high axial tension, the ACI equations can be extremely conservative.

## CONCLUSIONS

It is believed that the method presented in this paper is "integrated," "simplified," and gives "a physical significance" to the parameters being calculated. For example, the shear carried by tensile stresses in the concrete  $V_c$  is made a function of the longitudinal straining in the web of the member  $\epsilon_x$ . As  $\epsilon_x$  increases,  $V_c$  decreases. Increasing the magnitude of the moment or applying axial tension increases  $\epsilon_x$  and hence, decreases  $V_c$ . Applying axial compression or prestress or increasing the area of longitudinal reinforcement decreases  $\epsilon_x$  and hence, increases  $V_c$ .

A key feature of the new procedures is that they explicitly consider the influence of shear upon the longitudinal reinforcement. It is believed that if engineers understand that shear causes tension in the longitudinal reinforcement, they will avoid some of the more serious detailing errors that are sometimes made in current practice.

## ACKNOWLEDGMENTS

The development of the modified compression field theory was made possible by a series of grants from the Natural Sciences and Engineering Research Council of Canada and by support from the Networks of Centers of Excellence Program funded by the Minister of State, Science, and Technology, Canada. The authors would like to express their gratitude to these organizations for their support. The challenge of developing practical and comprehensive shear design provisions for the National Cooperative Highway Research Program's project "Development of Bridge Specifications" was the catalyst for the formulation of these proposals. The authors are also indebted to Dr. Khaldoun N. Rahal for his valuable assistance in performing the many calculations required to prepare Tables 1, 2, and 3.

## NOTATION

$A_{ps}$	= area of prestressed longitudinal reinforcement on flexural tension side of member
$A_s$	= area of longitudinal reinforcing bars on flexural tension side of member
$A_v$	= area of shear reinforcement within distance $s$
$a$	= maximum aggregate size
$b_v$	= effective web width taken as minimum web width within effective shear depth $d_v$
$d$	= distance from extreme compression fiber to centroid of longitudinal tension reinforcement
$d_v$	= effective shear depth taken as flexural lever arm which need not be taken less than $0.9d$ . For prestressed members, $d$ need not be taken less than $0.8h$ in determining $d_v$
$E_p$	= modulus of elasticity of prestressing tendons
$E_s$	= modulus of elasticity of reinforcing bars
$f_c'$	= specified compressive strength of concrete
$f_{cr}$	= cracking strength of concrete
$f_{po}$	= stress in prestressed tendon when surrounding concrete is at zero stress
$f_{se}$	= effective stress in prestressed tendon after all losses
$f_1$	= residual tensile stress in cracked concrete
$f_2$	= principal compressive stress in concrete
$f_{2max}$	= crushing strength of diagonally cracked concrete
$h$	= overall height of member
$M_u$	= factored moment taken as positive
$N_u$	= factored axial load taken as positive for tension, negative for compression
$s$	= spacing of shear reinforcement
$s_x$	= crack spacing parameter for members without stirrups
$s_{xe}$	= equivalent value of $s_x$ for beams where aggregate size is not $3/4$ in.
$V_c$	= shear strength provided by tensile stresses in cracked concrete

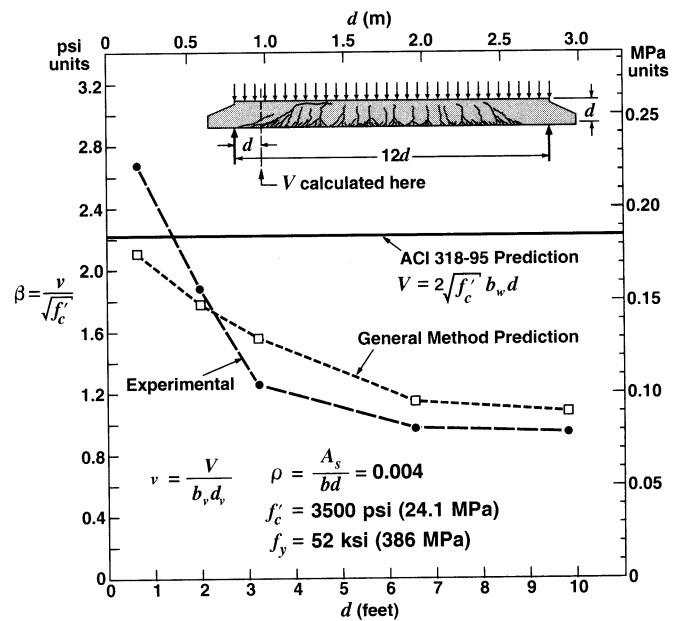


Fig. 10—Influence of member size and maximum aggregate size on shear stresses at failure

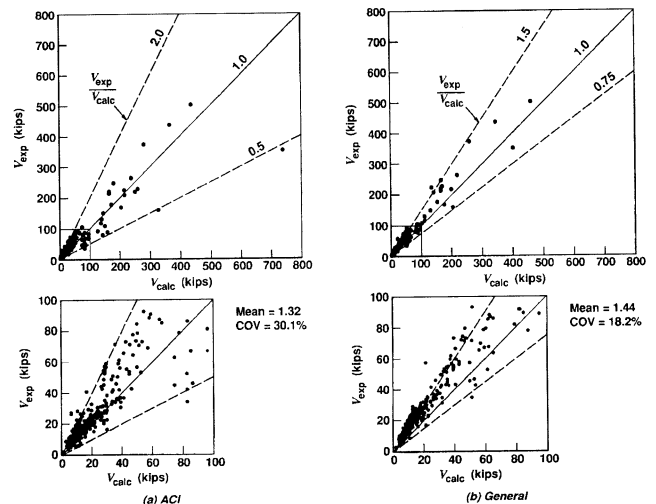


Fig. 11—Correlation of experimental and predicted failure shears for 528 tests

$V_n$	= nominal shear strength
$V_p$	= vertical component of prestressing
$V_s$	= shear strength provided by stirrups
$V_u$	= factored shear force taken as positive
$\beta$	= tensile stress factor indicating ability of cracked concrete to transmit shear
$\epsilon_1$	= principal tensile strain in cracked concrete
$\epsilon_2$	= principal compressive strain in cracked concrete
$\epsilon_c'$	= strain in concrete when $f_c'$ reaches $f_c'$
$\theta$	= angle of inclination of principal compressive stress in cracked concrete with respect to longitudinal axis of member
$\phi$	= strength reduction factor

## REFERENCES

1. ACI Committee 318, "Building Code Requirements for Reinforced Concrete (ACI 318-95) and Commentary ACI 318 R-95," American Concrete Institute, Detroit, 1995, 369 pp.
2. ACI-ASCE Committee 426, "Shear Strength of Reinforced Concrete Members," *Journal of the Structural Division*, ASCE, V. 99, No. ST6, June 1973, pp. 1091-1187.
3. ACI Committee 318, "Building Code Requirements for Reinforced

**Table 3—Experimental verification**

Reference	Date	Number and specimen type	Loading	Depth, in.	Concrete, psi	Stirrups $\frac{A_w f_y}{b_w s}$ psi	Experiment/predicted			
							ACI		General	
							Mean	Coefficient of variation, percent	Mean	Coefficient of variation, percent
Kani <sup>19</sup>	1979	68 rectangular beams	2 point loads on simple span	6 to 48	2230 to 5320	0	1.23	14.9	1.35	8.0
Kani <sup>19</sup>	1979	95 T-beams	2 point loads on simple span	12	2510 to 5550	0	1.60	11.5	1.63	10.1
Shioya <sup>15</sup>	1989	13 rectangular beams	Uniformly distributed load on simple span	5 to 124	2860 to 4130	0	0.86	42.9	0.98	25.1
Gupta <sup>20</sup>	1993	10 rectangular beams	End loads applying shear and compression	12	8700 to 9120	0 to 170	0.85	27.3	1.13	16.8
Adebar and Collins <sup>21</sup>	1996	7 rectangular columns	End loads applying shear and tension	12	6700 to 8500	0	2.75	51.4	0.90	12.8
Gregor and Collins <sup>22</sup>	1993	6 prestressed bridge girders	Uniformly distributed load on continuous span	36	6500 to 8400 psi	370 to 590	1.06	17.5	1.37	12.7
Collins and Végh <sup>23</sup>	1993	14 rectangular beams	Point loads on continuous span	11 to 36	7250 to 13,500	0 to 120	0.84	18.2	1.07	15.9
Griezic, Cook, and Mitchell <sup>24</sup>	1993	4 T-beams	Uniformly distributed load on simple span	16	5800	225 to 350	1.34	12.2	1.34	12.6
Haddadin, Hong, and Mattock <sup>25</sup>	1971	59 T-beams	Point loads on beams with tension or compression	18.5	1950 to 6500	0 to 700	1.61	32.3	1.45	18.7
Elzanaty, Nilson, and Slate <sup>26</sup>	1986	33 prestressed I-beams	2 point loads on simple span	14 and 18	6000 to 11,400	0 to 700	1.07	11.6	1.35	9.5
Pasley, Gogoi, Darwin, and McCabe <sup>27</sup>	1990	13 T-beams	Point loads on continuous span	18	4500	0 to 82	0.99	12.0	1.27	7.0
Mattock <sup>28</sup>	1969	31 rectangular beams	Point loads on beams with tension or compression	12	2200 to 8000	0	1.56	24.7	1.45	14.0
Bennett and Balasooriya <sup>29</sup>	1971	20 prestressed I-beams	2 point loads on simple span	10 and 18	4400 to 6460	630 to 1900	1.71	19.4	1.46	18.2
Bennett and Debaikay <sup>29</sup>	1974	22 prestressed I-beams	Point load on simple span	13	6000 to 10,500	103 to 5600	1.15	9.9	1.54	10.9
Moody, Viest, Elstner, and Hognestad <sup>31</sup>	1954	12 rectangular beams	Point load on simple span	12	880 to 4600	0	1.27	14.2	1.27	13.5
MacGregor <sup>32</sup>	1960	33 prestressed I-beams	Point load on simple span	12	2400 to 7000	0 to 470	1.09	25.8	1.54	22.5
Oleson, Sozen, and Siess <sup>33</sup>	1967	27 prestressed I-beams	Point load on simple span	12	2450 to 6700	0 to 350	1.06	18.8	1.59	15.3
Roller and Russell <sup>34</sup>	1990	10 rectangular beams	Point load on simple span	25 to 34	10,500 to 18,170	0 to 1176	1.05	20.0	1.19	13.5
Shahawy, Robinson, and Batchelor <sup>35</sup>	1993	39 full-size prestressed bridge girders	Point load on simple span	44	6000	165 to 1670	1.09	19.5	1.13	15.8
Yoon, Cook, and Mitchell <sup>36</sup>	1996	12 rectangular beams	Point load on simple span	30	5220 to 12,615	0 to 145	1.14	13.8	1.07	10.3
		528 beams				Average	1.32	33.7	1.39	19.7

Concrete," American Concrete Institute, Detroit, 1963, 144 pp.

4. ACI Committee 318, "Building Code Requirements for Reinforced Concrete," American Concrete Institute, Detroit, 1971, 78 pp.

5. Elstner, R. C., and Hognestad, E., "Laboratory Investigation of Rigid Frame Failure," *ACI JOURNAL*, *Proceedings* V. 53, No. 1, Jan.

1957, pp. 637-668.

6. Vecchio, F. J., and Collins, M. P., "Modified Compression Field Theory for Reinforced Concrete Elements Subjected to Shear," *ACI Structural Journal*, V. 83, No. 2, Mar.-Apr. 1986, pp. 219-231.

7. Collins, M. P., and Mitchell, D., *Prestressed Concrete Structures*,

**Table 3—Experimental verification**

Reference	Date	Number and specimen type	Loading	Depth, in.	Concrete, psi	Stirrups $A_w f_y$ $b_w s$ psi	Experiment/predicted			
							ACI		General	
							Mean	Coefficient of variation, percent	Mean	Coefficient of variation, percent
Kani <sup>19</sup>	1979	68 rectangular beams	2 point loads on simple span	6 to 48	2230 to 5320	0	1.23	14.9	1.35	8.0
Kani <sup>19</sup>	1979	95 T-beams	2 point loads on simple span	12	2510 to 5550	0	1.60	11.5	1.63	10.1
Shioya <sup>15</sup>	1989	13 rectangular beams	Uniformly distributed load on simple span	5 to 124	2860 to 4130	0	0.86	42.9	0.98	25.1
Gupta <sup>20</sup>	1993	10 rectangular beams	End loads applying shear and compression	12	8700 to 9120	0 to 170	0.85	27.3	1.13	16.8
Adebar and Collins <sup>21</sup>	1996	7 rectangular columns	End loads applying shear and tension	12	6700 to 8500	0	2.75	51.4	0.90	12.8
Gregor and Collins <sup>22</sup>	1993	6 prestressed bridge girders	Uniformly distributed load on continuous span	36	6500 to 8400 psi	370 to 590	1.06	17.5	1.37	12.7
Collins and Végh <sup>23</sup>	1993	14 rectangular beams	Point loads on continuous span	11 to 36	7250 to 13,500	0 to 120	0.84	18.2	1.07	15.9
Griezic, Cook, and Mitchell <sup>24</sup>	1993	4 T-beams	Uniformly distributed load on simple span	16	5800	225 to 350	1.34	12.2	1.34	12.6
Haddadin, Hong, and Mattock <sup>25</sup>	1971	59 T-beams	Point loads on beams with tension or compression	18.5	1950 to 6500	0 to 700	1.61	32.3	1.45	18.7
Elzanaty, Nilson, and Slate <sup>26</sup>	1986	33 prestressed I-beams	2 point loads on simple span	14 and 18	6000 to 11,400	0 to 700	1.07	11.6	1.35	9.5
Pasley, Gogoi, Darwin, and McCabe <sup>27</sup>	1990	13 T-beams	Point loads on continuous span	18	4500	0 to 82	0.99	12.0	1.27	7.0
Mattock <sup>28</sup>	1969	31 rectangular beams	Point loads on beams with tension or compression	12	2200 to 8000	0	1.56	24.7	1.45	14.0
Bennett and Balasooriya <sup>29</sup>	1971	20 prestressed I-beams	2 point loads on simple span	10 and 18	4400 to 6460	630 to 1900	1.71	19.4	1.46	18.2
Bennett and Debaikye <sup>29</sup>	1974	22 prestressed I-beams	Point load on simple span	13	6000 to 10,500	103 to 5600	1.15	9.9	1.54	10.9
Moody, Viest, Elstner, and Hognestad <sup>31</sup>	1954	12 rectangular beams	Point load on simple span	12	880 to 4600	0	1.27	14.2	1.27	13.5
MacGregor <sup>32</sup>	1960	33 prestressed I-beams	Point load on simple span	12	2400 to 7000	0 to 470	1.09	25.8	1.54	22.5
Oleson, Sozen, and Siess <sup>33</sup>	1967	27 prestressed I-beams	Point load on simple span	12	2450 to 6700	0 to 350	1.06	18.8	1.59	15.3
Roller and Russell <sup>34</sup>	1990	10 rectangular beams	Point load on simple span	25 to 34	10,500 to 18,170	0 to 1176	1.05	20.0	1.19	13.5
Shahawy, Robinson, and Batchelor <sup>35</sup>	1993	39 full-size prestressed bridge girders	Point load on simple span	44	6000	165 to 1670	1.09	19.5	1.13	15.8
Yoon, Cook, and Mitchell <sup>36</sup>	1996	12 rectangular beams	Point load on simple span	30	5220 to 12,615	0 to 145	1.14	13.8	1.07	10.3
		528 beams				Average	1.32	33.7	1.39	19.7

Concrete," American Concrete Institute, Detroit, 1963, 144 pp.

4. ACI Committee 318, "Building Code Requirements for Reinforced Concrete," American Concrete Institute, Detroit, 1971, 78 pp.

5. Elstner, R. C., and Hognestad, E., "Laboratory Investigation of Rigid Frame Failure," ACI JOURNAL, *Proceedings* V. 53, No. 1, Jan.

1957, pp. 637-668.

6. Vecchio, F. J., and Collins, M. P., "Modified Compression Field Theory for Reinforced Concrete Elements Subjected to Shear," *ACI Structural Journal*, V. 83, No. 2, Mar.-Apr. 1986, pp. 219-231.

7. Collins, M. P., and Mitchell, D., *Prestressed Concrete Structures*,

Prentice Hall, Englewood Cliffs, New Jersey, 1991, 766 pp.

8. MTO, OHBDC Committee, *Ontario Highway Bridge Design Code*, 3rd Edition, Ontario Ministry of Transportation, Downsview, 1991, 370 pp.

9. CSA Committee A23.3, "Design of Concrete Structures: Structures (Design)—A National Standard of Canada," Canadian Standards Association, Rexdale, Dec. 1994, 199 pp.

10. "AASHTO LRFD Bridge Design Specifications and Commentary," First Edition, American Association of State Highway and Transportation Officials, Washington, D.C., 1994, 1091 pp.

11. Vecchio, F. J., and Collins, M. P., "Predicting the Response of Reinforced Concrete Beams Subjected to Shear Using Modified Compression Field Theory," *ACI Structural Journal*, V. 85, No. 3, May-June 1988, pp. 258-268.

12. Cook, W. D., and Mitchell, D., "Studies of Disturbed Regions near Discontinuities in Reinforced Concrete Members," *ACI Structural Journal*, V. 85, No. 2, Mar.-Apr. 1988, pp. 206-216.

13. Vecchio, F. J., "Nonlinear Finite Element Analysis of Reinforced Concrete Membranes," *ACI Structural Journal*, V. 86, No. 1, Jan.-Feb. 1989, pp. 26-35.

14. Shiroya, T.; Iguro, M.; Nojiri, Y.; Akiyama, H.; and Okada, T., "Shear Strength of Large Reinforced Concrete Beams," *Fracture Mechanics: Application to Concrete*, SP-118, American Concrete Institute, Detroit, 1989, 309 pp.

15. Shiroya, T., "Shear Properties of Large Reinforced Concrete Member," *Special Report of Institute of Technology, Shimizu Corporation*, No. 25, Feb. 1989, 198 pp.

16. ACI-ASCE Committee 326, "Shear and Diagonal Tension," *ACI JOURNAL, Proceedings* V. 59, Jan., Feb., and Mar. 1962, pp. 1-30, 277-344, and 352-396.

17. Collins, M. P., and Mitchell, D., "Rational Approach to Shear Design—The 1984 Canadian Code Provisions," *ACI Structural Journal*, V. 83, No. 6, Nov.-Dec. 1986, pp. 925-933.

18. Schlaich, J.; Schäfer, K.; and Jennewein, M., "Towards a Consistent Design of Reinforced Concrete Structures," *PCI Journal*, V. 32, No. 3, May-June 1987, pp. 74-150.

19. Kani, M. W.; Huggins, M. W.; and Wittkopp, R. R., *Kani on Shear in Reinforced Concrete*, Department of Civil Engineering, University of Toronto, Toronto, 1979, 225 pp.

20. Gupta, P., and Collins, M. P., "Behavior of Reinforced Concrete Members Subjected to Shear and Compression," MASC thesis, Department of Civil Engineering, University of Toronto, 1993.

21. Adebar, P., and Collins, M. P., "Shear Strength of Members without Transverse Reinforcement," *Canadian Journal of Civil Engineering*, V. 23, No. 1, Feb. 1996, pp. 30-41.

22. Gregor, T., and Collins, M. P., "Tests of Large Partially Prestressed

Concrete Girders," *ACI Structural Journal* (submitted for publication).

23. Collins, M. P.; Mitchell, D.; and MacGregor, J. G., "Structural Design Considerations for High-Strength Concrete," *Concrete International*, May 1993, pp. 27-34.

24. Griezic, A.; Cook, W. D.; and Mitchell, D., "Tests to Determine Performance of Deformed Welded Wire Fabric Stirrups," *ACI Structural Journal*, V. 91, No. 2, Mar.-Apr. 1994, pp. 211-220.

25. Haddadin, M. J.; Hong, S. T.; and Mattock, A. H., "Stirrup Effectiveness in Reinforced Concrete Beams with Axial Force," *Journal of the Structural Division*, Proceedings ASCE, V. 97, No. ST9, Sept. 1971, pp. 2277-2297.

26. Elzanaty, A. H.; Nilson, A. H.; and Slate, F. O., "Shear Capacity of Prestressed Concrete Beams Using High-Strength Concrete," *ACI Structural Journal*, V. 83, No. 3, May-June 1986, pp. 359-368.

27. Pasley, G. P.; Gogoi, S.; Darwin, D.; and McCabe, S. L., "Shear Strength of Continuous Lightly Reinforced T-Beams," *SM Report* No. 26, University of Kansas, Dec. 1990, 151 pp.

28. Mattock, A. H., "Diagonal Tension Cracking in Concrete Beams with Axial Forces," *Journal of the Structural Division*, Proceedings ASCE, V. 95, No. ST9, Sept. 1969, pp. 1887-1990.

29. Bennett, E. W., and Balasooriya, B. M. A., "Shear Strength of Prestressed Beams with Thin Webs Failing in Inclined Compression," *ACI JOURNAL, Proceedings* V. 68, No. 3, Mar. 1971, pp. 204-212.

30. Bennett, E. W., and Debaiky, S. Y., "High-Strength Steel as Shear Reinforcement in Prestressed Concrete Beams," *Shear in Reinforced Concrete*, SP-42, American Concrete Institute, 1974, pp. 231-248.

31. Moody, K. G.; Viest, M.; Elstner, R. C.; and Hognestad, E., "Shear Strength of Reinforced Concrete Beams: Part 1—Tests of Simple Beams," *ACI JOURNAL, Proceedings* V. 26, No. 4, Dec. 1954, pp. 317-332.

32. MacGregor, J. G., "Strength and Behavior of Prestressed Concrete Beams with Web Reinforcement," PhD thesis, Department of Civil Engineering, University of Illinois, 1960, 295 pp.

33. Oleson, S. Ø.; Sozen, M. A.; and Siess, C. P., "Investigation of Prestressed Reinforced Concrete for Highway Bridges: Part IV—Strength in Shear of Beams with Web Reinforcement," *Bulletin* No. 493, University of Illinois Engineering Experiment Station, Urbana, 1967.

34. Roller, J. J., and Russell, H. G., "Shear Strength of High-Strength Concrete Beams with Web Reinforcement," *ACI Structural Journal*, V. 87, No. 2, Mar.-Apr. 1990, pp. 191-198.

35. Shahawy, M.; Robinson, B.; and Batchelor, B. deV., "Investigation of Shear Strength of Prestressed Concrete AASHTO Type II Girders," Structures Research Center, Florida Dept. of Transportation, Jan. 1993, 182 pp.

36. Yoon, Y. S.; Cook, W. D.; and Mitchell, D., "Minimum Shear Reinforcement in Normal, Medium, and High-Strength Concrete Beams," *ACI Structural Journal* (accepted for publication).